

3-Way or More Applications (Multi-location)
Remote Devices

Cat. No. VP00R-10, Coordinating Dimmer Remote
Cat. No. VP00R-1L, Matching Dimmer Remote
Cat. No. VP0SR-10, Coordinating Switch Remote
Cat. No. VP0SR-1L, Matching Switch Remote
120VAC, 60Hz

INSTALLATION INSTRUCTIONS

WARNINGS AND CAUTIONS:

- To be installed and/or used in accordance with appropriate electrical codes and regulations.
- If you are unsure about any part of these instructions, consult a qualified electrician.
- To avoid overheating and possible damage to this device and other equipment, do not install to control a receptacle, fluorescent lighting, a motor- or a transformer-operated appliance.
- For Hi-lume® or Eco-10® (EcoSeries) electronic ballast applications, use instruction sheet that comes with the dimmer for multi-location applications.
- Vizia +™ remotes are not compatible with standard 3-way or 4-way switches. They must be used with compatible Vizia +™ or Vizia rf +™ devices for multi-location switching.

WARNINGS AND CAUTIONS:

- Use only one (1) Vizia +™ dimmer in a multi-location circuit with up to 9 coordinating remotes without LEDs or up to 4 matching remotes with LEDs. The remote(s) will turn the light on at the brightness level selected at the dimmer.
- Recommended minimum wall box depth is 2-1/2".
- Maximum wire length from dimmer to all installed remotes cannot exceed 300 ft (90 m).
- Disconnect power at circuit breaker or fuse when servicing, installing or removing fixture.
- Use this device only with copper or copper clad wire. With aluminum wire use only devices marked CO/ALR or CU/AL.

Tools needed to install your Remote:

- Slotted/Phillips Screwdriver
- Pliers
- Cutters
- Electrical Tape
- Pencil
- Ruler

Changing the color of your Device:
Your device may include color options. To change color of the face proceed as follows:

Push in side at tab to release

Line up tabs and press in sides one at a time to attach

INSTALLING YOUR REMOTE

NOTE: Use check boxes when Steps are completed.

Step 1 **WARNING: TO AVOID FIRE, SHOCK, OR DEATH; TURN OFF POWER** at circuit breaker or fuse and test that power is off before wiring!

Step 2 **Identifying your wiring application (most common):**

NOTE: If the wiring in the wall box does not resemble any of these configurations, consult a qualified electrician.

- 3-Way**
- Line or Load (See important instruction below)
 - Neutral
 - Ground
 - First Traveler – note color
 - Second Traveler – note color
- NOTE: For matching remote w/LEDs installation, the **First Traveler** becomes Line Hot.
- IMPORTANT:**
For 3-Way applications, note that one of the screw terminals from the old switch being removed will usually be a different color (Black) or labeled Common. Tag that wire with electrical tape and identify as the common (Line or Load) in both the dimmer wall box and remote wall box.
- For 4-Way applications,** note that the old switch being removed will have 4 screws plus a ground screw. Tag the two same color insulated wires with electrical tape.

Step 3 **Preparing and connecting wires:**
This remote can be wired using side wire terminal screws or through backwire openings. Choose appropriate wire stripping specifications accordingly.

Cut (if necessary)

Step 2 cont'd

Side Wire Connection
Side wire terminals accept #14 AWG solid copper wire only.

Back Wire (either hole may be used)
Back wire openings use #14-12 AWG solid copper wire only.

5/8" (1.6 cm)

Strip Gage (measure bare wire here or use gage on back of the dimmer)

• Make sure that the ends of the wires from the wall box are straight (cut if necessary).

• Remove insulation from each wire in the wall box as shown.

Step 4a **3-Way Wiring with Matching Remote (w/LEDs) Application:**
NOTE: Incandescent and Magnetic Low Voltage installations only.
NOTE: Screw terminal dimmer depicted.

Step 4a **3-Way Wiring with Matching Remote (w/LEDs) Application:**
NOTE: The dimmer must be installed in a wall box that has a Load connection. The matching remote must be installed in a wall box with a Line Hot connection and a Neutral connection. A Neutral wire to the matching remote needs to be added as shown.
If you are unsure about any part of these instructions, consult a qualified electrician.
NOTE: Maximum wire length from dimmer to all installed remotes cannot exceed 300 ft.

Wiring Matching Remote (wall box with Line Hot connection):
Connect wires per WIRING DIAGRAM as follows:

- Green or bare copper wire in wall box to Green terminal screw.
- Line Hot (common) wall box wire identified (tagged) when removing old switch and First Traveler to remote terminal screw marked "BK" or the Black dimmer lead.
- Second Traveler wall box wire from dimmer to remote terminal screw marked "YL/RD" (note wire color). This traveler from the remote must go to the terminal screw on the dimmer marked "YL/RD" or the Yellow/Red dimmer lead.
- Line Neutral wall box to remote terminal screw marked "WH".

Wiring Dimmer (wall box with Load connection):
Connect wires per WIRING DIAGRAM as follows:

- Green or bare copper wire in wall box to Green terminal screw or Green dimmer lead.
- Load wall box wire identified (tagged) when removing old switch to dimmer terminal screw marked "RD" or the Red dimmer lead.
- First Traveler Line Hot to dimmer terminal screw marked "BK" or the Black dimmer lead.
- Remove Red insulating label from terminal screw marked "YL/RD" or Yellow/Red dimmer lead.
- Second Traveler wall box wire (note color as above) to dimmer terminal screw marked "YL/RD" or the Yellow/Red dimmer lead.
- This traveler from the dimmer must go to the terminal screw on the remote marked "YL/RD".
- Line Neutral wall box to remote terminal screw marked "WH".

Step 4a **3-Way Wiring with Matching Remote (w/LEDs) Application:**
NOTE: Electronic Low Voltage, Mark 10™, Quiet Fan Speed and Electronic Switch installations only.
NOTE: Dimmer is depicted.

Wiring Matching Remote (wall box with Line Hot connection):
Connect wires per WIRING DIAGRAM as follows:

- Green or bare copper wire in wall box to Green terminal screw.
- Line Hot (common) wall box wire identified (tagged) when removing old switch and First Traveler to remote terminal screw marked "BK" or the Black dimmer lead.
- Second Traveler wall box wire from dimmer to remote terminal screw marked "YL/RD" (note wire color). This traveler from the remote must go to the terminal screw on the dimmer marked "YL/RD" or the Yellow/Red dimmer lead.
- Line Neutral wall box to remote terminal screw marked "WH".

Wiring Dimmer (wall box with Load connection):
Connect wires per WIRING DIAGRAM as follows:

- Green or bare copper wire in wall box to Green terminal screw.
- Load wall box wire identified (tagged) when removing old switch to terminal screw marked "BK" or Black control lead.
- First Traveler wall box wire (note color as above) to terminal screw marked "RD" or Red control lead.
- Remove Red insulating label from terminal screw marked "YL/RD" or Yellow/Red control lead.
- Second Traveler wall box wire to terminal screw marked "YL/RD" or Yellow/Red control lead.
- This traveler from the control must go to the terminal screw on the remote marked "YL/RD".
- Line neutral wall box wire to terminal screw marked "WH" or White control lead.

Step 4c **3-Way Wiring with Matching Remote (w/LEDs) for Controls with Neutral Connection Application:**
NOTE: Electronic Low Voltage, Mark 10™, Quiet Fan Speed and Electronic Switch installations only.
NOTE: Dimmer is depicted.

Step 4b **3-Way Wiring with Coordinating Remote (no LEDs) Application:**
NOTE: Incandescent and Magnetic Low Voltage installations only. NOTE: Screw terminal dimmer depicted.

Step 4b **3-Way Wiring with Coordinating Remote (no LEDs) Application:**
NOTE: When using the coordinating remote without LEDs, the dimmer can be installed on either the Line or Load side of the 3-way circuit.
NOTE: Maximum wire length from dimmer to all installed remotes cannot exceed 300 ft (90 m).

- Green or bare copper wire in wall box to Green terminal screw or Green dimmer lead.
- Line Hot (common) wall box wire identified (tagged) when removing old switch to dimmer terminal screw marked "BK" or Black dimmer lead.
- First Traveler wall box wire to terminal screw marked "RD" or Red dimmer lead (note wire color). This traveler from the dimmer must go to the terminal screw on the remote marked "RD".
- Remove Red insulating label from terminal screw marked "YL/RD" or Yellow/Red dimmer lead.
- Second Traveler wall box wire to terminal screw marked "YL/RD" or Yellow/Red dimmer lead (note wire color). This traveler from the dimmer must go to the terminal screw on the remote marked "YL/RD".

WIRING COORDINATING REMOTE:
Connect wires per WIRING DIAGRAM as follows:

- Green or bare copper wire in wall box to Green terminal screw.
- Load wall box wire identified (tagged) when removing old switch to terminal screw marked "RD" or Red control lead.
- First Traveler Line Hot to terminal screw marked "BK" or Black control lead.
- Remove Red insulating label from terminal screw marked "YL/RD" or Yellow/Red control lead.
- Second Traveler wall box wire to terminal screw marked "YL/RD" or Yellow/Red control lead.
- This traveler from the control must go to the terminal screw on the remote marked "YL/RD".
- Line neutral wall box wire to terminal screw marked "WH" or White control lead.

Step 4c **3-Way Wiring with Matching Remote (w/LEDs) for Controls with Neutral Connection Application:**
NOTE: Electronic Low Voltage, Mark 10™, Quiet Fan Speed and Electronic Switch installations only.
NOTE: Dimmer is depicted.

Wiring Matching Remote (wall box with Line Hot connection):
Connect wires per WIRING DIAGRAM as follows:

- Green or bare copper wire in wall box to Green terminal screw.
- Line Hot (common) wall box wire identified (tagged) when removing old switch and First Traveler to remote terminal screw marked "BK" or the Black dimmer lead.
- Second Traveler wall box wire from dimmer to remote terminal screw marked "YL/RD" (note wire color). This traveler from the remote must go to the terminal screw on the dimmer marked "YL/RD" or the Yellow/Red dimmer lead.
- Line Neutral wall box to remote terminal screw marked "WH".

Wiring Dimmer (wall box with Load connection):
Connect wires per WIRING DIAGRAM as follows:

- Green or bare copper wire in wall box to Green terminal screw.
- Load wall box wire identified (tagged) when removing old switch to terminal screw marked "BK" or Black control lead.
- First Traveler wall box wire (note color as above) to terminal screw marked "RD" or Red control lead.
- Remove Red insulating label from terminal screw marked "YL/RD" or Yellow/Red control lead.
- Second Traveler wall box wire to terminal screw marked "YL/RD" or Yellow/Red control lead.
- This traveler from the control must go to the terminal screw on the remote marked "YL/RD".
- Line neutral wall box wire to terminal screw marked "WH" or White control lead.

Step 4c **3-Way Wiring with Matching Remote (w/LEDs) for Controls with Neutral Connection Application:**
NOTE: Electronic Low Voltage, Mark 10™, Quiet Fan Speed and Electronic Switch installations only.
NOTE: Dimmer is depicted.

Wiring Matching Remote (wall box with Line Hot connection):
Connect wires per WIRING DIAGRAM as follows:

- Green or bare copper wire in wall box to Green terminal screw.
- Line Hot (common) wall box wire identified (tagged) when removing old switch and First Traveler to remote terminal screw marked "BK" or the Black dimmer lead.
- Second Traveler wall box wire from dimmer to remote terminal screw marked "YL/RD" (note wire color). This traveler from the remote must go to the terminal screw on the dimmer marked "YL/RD" or the Yellow/Red dimmer lead.
- Line Neutral wall box to remote terminal screw marked "WH".

Wiring Dimmer (wall box with Load connection):
Connect wires per WIRING DIAGRAM as follows:

- Green or bare copper wire in wall box to Green terminal screw.
- Load wall box wire identified (tagged) when removing old switch to terminal screw marked "BK" or Black control lead.
- First Traveler wall box wire (note color as above) to terminal screw marked "RD" or Red control lead.
- Remove Red insulating label from terminal screw marked "YL/RD" or Yellow/Red control lead.
- Second Traveler wall box wire to terminal screw marked "YL/RD" or Yellow/Red control lead.
- This traveler from the control must go to the terminal screw on the remote marked "YL/RD".
- Line neutral wall box wire to terminal screw marked "WH" or White control lead.

Step 4c **3-Way Wiring with Matching Remote (w/LEDs) for Controls with Neutral Connection Application:**
NOTE: Electronic Low Voltage, Mark 10™, Quiet Fan Speed and Electronic Switch installations only.
NOTE: Dimmer is depicted.

Wiring Matching Remote (wall box with Line Hot connection):
Connect wires per WIRING DIAGRAM as follows:

- Green or bare copper wire in wall box to Green terminal screw.
- Line Hot (common) wall box wire identified (tagged) when removing old switch and First Traveler to remote terminal screw marked "BK" or the Black dimmer lead.
- Second Traveler wall box wire from dimmer to remote terminal screw marked "YL/RD" (note wire color). This traveler from the remote must go to the terminal screw on the dimmer marked "YL/RD" or the Yellow/Red dimmer lead.
- Line Neutral wall box to remote terminal screw marked "WH".

Wiring Dimmer (wall box with Load connection):
Connect wires per WIRING DIAGRAM as follows:

- Green or bare copper wire in wall box to Green terminal screw.
- Load wall box wire identified (tagged) when removing old switch to terminal screw marked "BK" or Black control lead.
- First Traveler wall box wire (note color as above) to terminal screw marked "RD" or Red control lead.
- Remove Red insulating label from terminal screw marked "YL/RD" or Yellow/Red control lead.
- Second Traveler wall box wire to terminal screw marked "YL/RD" or Yellow/Red control lead.
- This traveler from the control must go to the terminal screw on the remote marked "YL/RD".
- Line neutral wall box wire to terminal screw marked "WH" or White control lead.

Step 4d **3-Way Wiring with Coordinating Remote (no LEDs) for Controls with Neutral Connection Application:**
NOTE: Electronic Low Voltage, Mark 10™, Quiet Fan Speed and Electronic Switch installations only.
NOTE: Dimmer is depicted.

WIRING CONTROL:
Connect wires per WIRING DIAGRAM as follows:

- Green or bare copper wire in wall box to Green terminal screw or Green control lead.
- Line Hot (common) wall box wire identified (tagged) when removing old switch to terminal screw marked "BK" or Black control lead.
- First Traveler wall box wire to terminal screw marked "RD" or Red control lead (note wire color).
- Remove Red insulating label from terminal screw marked "YL/RD" or Yellow/Red control lead.
- Second Traveler wall box wire to terminal screw marked "YL/RD" or Yellow/Red control lead.
- This traveler from the control must go to the terminal screw on the remote marked "YL/RD".
- Line Neutral wall box wire to terminal screw marked "WH" or White control lead.

Step 4d **3-Way Wiring with Coordinating Remote (no LEDs) for Controls with Neutral Connection Application:**
NOTE: Electronic Low Voltage, Mark 10™, Quiet Fan Speed and Electronic Switch installations only.
NOTE: Dimmer is depicted.

WIRING CONTROL:
Connect wires per WIRING DIAGRAM as follows:

- Green or bare copper wire in wall box to Green terminal screw or Green control lead.
- Line Hot (common) wall box wire identified (tagged) when removing old switch to terminal screw marked "BK" or Black control lead.
- First Traveler wall box wire to terminal screw marked "RD" or Red control lead (note wire color).
- Remove Red insulating label from terminal screw marked "YL/RD" or Yellow/Red control lead.
- Second Traveler wall box wire to terminal screw marked "YL/RD" or Yellow/Red control lead.
- This traveler from the control must go to the terminal screw on the remote marked "YL/RD".
- Line Neutral wall box wire to terminal screw marked "WH" or White control lead.

Step 4d **3-Way Wiring with Coordinating Remote (no LEDs) for Controls with Neutral Connection Application:**
NOTE: Electronic Low Voltage, Mark 10™, Quiet Fan Speed and Electronic Switch installations only.
NOTE: Dimmer is depicted.

WIRING CONTROL:
Connect wires per WIRING DIAGRAM as follows:

- Green or bare copper wire in wall box to Green terminal screw or Green control lead.
- Line Hot (common) wall box wire identified (tagged) when removing old switch to terminal screw marked "BK" or Black control lead.
- First Traveler wall box wire to terminal screw marked "RD" or Red control lead (note wire color).
- Remove Red insulating label from terminal screw marked "YL/RD" or Yellow/Red control lead.
- Second Traveler wall box wire to terminal screw marked "YL/RD" or Yellow/Red control lead.
- This traveler from the control must go to the terminal screw on the remote marked "YL/RD".
- Line Neutral wall box wire to terminal screw marked "WH" or White control lead.

Step 4d **3-Way Wiring with Coordinating Remote (no LEDs) for Controls with Neutral Connection Application:**
NOTE: Electronic Low Voltage, Mark 10™, Quiet Fan Speed and Electronic Switch installations only.
NOTE: Dimmer is depicted.

WIRING CONTROL:
Connect wires per WIRING DIAGRAM as follows:

- Green or bare copper wire in wall box to Green terminal screw or Green control lead.
- Line Hot (common) wall box wire identified (tagged) when removing old switch to terminal screw marked "BK" or Black control lead.
- First Traveler wall box wire to terminal screw marked "RD" or Red control lead (note wire color).
- Remove Red insulating label from terminal screw marked "YL/RD" or Yellow/Red control lead.
- Second Traveler wall box wire to terminal screw marked "YL/RD" or Yellow/Red control lead.
- This traveler from the control must go to the terminal screw on the remote marked "YL/RD".
- Line Neutral wall box wire to terminal screw marked "WH" or White control lead.

Step 4d **3-Way Wiring with Coordinating Remote (no LEDs) for Controls with Neutral Connection Application:**
NOTE: Electronic Low Voltage, Mark 10™, Quiet Fan Speed and Electronic Switch installations only.
NOTE: Dimmer is depicted.

WIRING CONTROL:
Connect wires per WIRING DIAGRAM as follows:

- Green or bare copper wire in wall box to Green terminal screw or Green control lead.
- Line Hot (common) wall box wire identified (tagged) when removing old switch to terminal screw marked "BK" or Black control lead.
- First Traveler wall box wire to terminal screw marked "RD" or Red control lead (note wire color).
- Remove Red insulating label from terminal screw marked "YL/RD" or Yellow/Red control lead.
- Second Traveler wall box wire to terminal screw marked "YL/RD" or Yellow/Red control lead.
- This traveler from the control must go to the terminal screw on the remote marked "YL/RD".
- Line Neutral wall box wire to terminal screw marked "WH" or White control lead.

Step 4d cont'd

WIRING COORDINATING REMOTE:
Connect wires per WIRING DIAGRAM as follows:
NOTE: "BK" and "RD" terminals on coordinating remote are unused. Tighten both screws.
NOTE: Maximum wire length from control to last remote is 300 ft (90 m).

- Green or bare copper wire in wall box to Green terminal screw.
- Load wall box wire identified (tagged) when removing old switch to First Traveler (note color as above).
- Second Traveler wall box wire (note color as above) to terminal screw marked "YL/RD". This traveler from the remote must go to the terminal screw marked "YL/RD" or Yellow/Red control lead.
- Remove White insulating label from terminal screw marked "WH".
- Line Neutral wall box wire to terminal screw marked "WH".
- Proceed to Step 6.

Step 5a **4-Way Wiring with Matching Remote (w/LEDs) Application:**
NOTE: Incandescent and Magnetic Low Voltage installations only.
NOTE: Screw terminal dimmer depicted.

Step 5a **4-Way Wiring with Matching Remote (w/LEDs) Application:**
NOTE: The dimmer must be installed in a wall box that has a Load connection. The matching remote must be installed in a wall box with a Line Hot connection and a Neutral connection. A Neutral wire to the matching remote needs to be added as shown.
If you are unsure about any part of these instructions, consult a qualified electrician.
NOTE: Maximum wire length from dimmer to all installed remotes cannot exceed 300 ft (90 m).

WIRING MATCHING REMOTE (4-Way wall box with Line Hot connection):
Connect wires per WIRING DIAGRAM as follows:

- Green or bare copper wire in wall box to Green terminal screw.
- First Traveler and Third Traveler wall box wire from dimmer in the 3-way box to remote terminal screw marked "BK" in the 4-way box, and to the terminal screw marked "BK" of the remaining remote in the 3-way box.
- Second Traveler (tagged) and Fourth Traveler (tagged) wall box wire from dimmer in the 3-way box to remote terminal screw marked "YL/RD" in the 4-way box, and to the terminal screw marked "YL/RD" of the remaining remote in the 3-way box (note wire colors). This traveler from the remotes must go to the terminal screw on the dimmer marked "YL/RD" or the Yellow/Red dimmer lead.
- Line Neutral wall box wire to remote terminal screw marked "WH".

Step 5a **4-Way Wiring with Matching Remote (w/LEDs) Application:**
NOTE: The control must be installed in a wall box that has a Line Hot connection. The matching remote must be installed in a wall box with a Line Hot connection and a Neutral connection. A Neutral wire to the matching remote needs to be added as shown.
If you are unsure about any part of these instructions, consult a qualified electrician.
NOTE: Maximum wire length from dimmer to all installed remotes cannot exceed 300 ft (90 m).

WIRING MATCHING REMOTE (3-Way wall box with Line Hot connection):
Connect wires per WIRING DIAGRAM as follows:

- Green or bare copper wire in wall box to Green terminal screw.
- Line Hot (common) wall box wire identified (tagged) when removing old switch and First Traveler dimmer terminal screw marked "BK" or the Black dimmer lead.
- Second Traveler wall box wire from dimmer to remote terminal screw marked "YL/RD" (note wire color as above). This traveler from the remote must go to the terminal screw on the dimmer marked "YL/RD" or the Yellow/Red dimmer lead.
- Line Neutral wall box wire to remote terminal screw marked "WH".

Step 5a **4-Way Wiring with Matching Remote (w/LEDs) Application:**
NOTE: The control must be installed in a wall box that has a Line Hot connection. The matching remote must be installed in a wall box with a Line Hot connection and a Neutral connection. A Neutral wire to the matching remote needs to be added as shown.
If you are unsure about any part of these instructions, consult a qualified electrician.
NOTE: Maximum wire length from dimmer to all installed remotes cannot exceed 300 ft (90 m).

WIRING MATCHING REMOTE (3-Way wall box with Line Hot connection):
Connect wires per WIRING DIAGRAM as follows:

- Green or bare copper wire in wall box to Green terminal screw.
- Line Hot (common) wall box wire identified (tagged) when removing old switch and First Traveler dimmer terminal screw marked "BK" or the Black dimmer lead.
- Second Traveler wall box wire from dimmer to remote terminal screw marked "YL/RD" (note wire color as above). This traveler from the remote must go to the terminal screw on the dimmer marked "YL/RD" or the Yellow/Red dimmer lead.
- Line Neutral wall box wire to remote terminal screw marked "WH".

Step 5a cont'd 4-Way Wiring with Matching Remote (w/LEDs) Application:

WIRING DIMMER (3-Way wall box with Load connection):
Connect wires per WIRING DIAGRAM as follows:

- Green or bare copper wire in wall box to Green terminal screw or Green dimmer lead.
- Load wall box wire identified (tagged) when removing old switch to dimmer terminal screw marked "RD" or the Red dimmer lead.
- First Traveler Line Hot to dimmer terminal screw marked "BK" or the Black dimmer lead.
- Remove Red insulating label from terminal screw marked "YL/RD" or the Yellow/Red dimmer lead.
- Second Traveler wall box wire (note color as above) to dimmer terminal screw marked "YL/RD" or the Yellow/Red dimmer lead. This traveler from the dimmer must go to the terminal screw on the remote marked "YL/RD".
- Proceed to Step 6.

Step 5b 4-Way Wiring with Coordinating Remote (no LEDs) Application:

NOTE: Incandescent and Magnetic Low Voltage installations only.
NOTE: Screw terminal dimmer depicted.

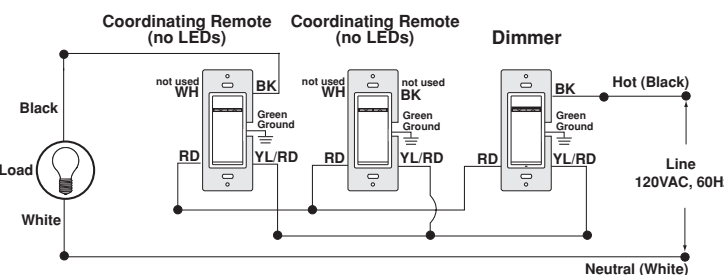
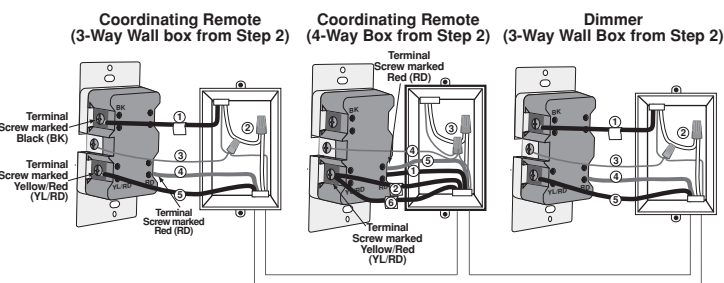

WIRING COORDINATING REMOTE (4-Way box):
Connect wires per WIRING DIAGRAM as follows:

NOTE: Maximum wire length from dimmer to last remote is 300 ft (90 m).

- Green or bare copper wire in wall box to Green terminal screw.
- First Traveler and Third Traveler wall box wire (note wire colors) to terminal screw marked "RD". These travelers from the remote in the 4-way box must go to the terminal screw on the dimmer marked "RD" or Red dimmer lead, and to the terminal screw marked "RD" of the remaining remote in the 3-way box.
- Second Traveler (tagged) and Fourth Traveler (tagged) wall box wire (note wire colors) to terminal screw marked "YL/RD". These travelers from the remote in the 4-way box must go to the terminal screw on the dimmer marked "YL/RD" or the Yellow/Red dimmer lead, and to the terminal screw marked "YL/RD" of the remaining remote in the 3-way box.
- Remote terminal screw marked "WH" should have White insulation label affixed.
NOTE: If insulating label is not affixed to terminal screw marked "WH", use electrical tape to cover. Remote terminal screw marked "BK" is not used. Use electrical tape to cover.

WIRING DIMMER (3-Way box):
Connect wires per WIRING DIAGRAM as follows:

NOTE: When using the coordinating remote without LEDs, the dimmer can be installed on either the Line or Load side of the 3-way circuit.

NOTE: Maximum wire length from dimmer to all installed remotes cannot exceed 300 ft (90 m).

- Green or bare copper wire in wall box to Green terminal screw or Green dimmer lead.
- Line Hot (common) wall box wire identified (tagged) when removing old switch to dimmer terminal screw marked "BK" or Black dimmer lead.
- First Traveler wall box wire (note wire color as above) to dimmer terminal screw marked "RD" or Red dimmer lead (note wire color as above). This traveler from the dimmer must go to the terminal screw on the remote marked "RD".
- Remove Red insulating label from terminal screw marked "YL/RD" or Yellow/Red dimmer lead.
- Second Traveler wall box wire to dimmer terminal screw marked "YL/RD" or Yellow/Red dimmer lead (note wire color as above). This traveler from the dimmer must go to the terminal screw on the remote marked "YL/RD".

WIRING COORDINATING REMOTE (3-Way box):
Connect wires per WIRING DIAGRAM as follows:

NOTE: Maximum wire length from dimmer to last remote is 300 ft (90 m).

- Green or bare copper wire in wall box to Green terminal screw.
- Load wall box wire identified (tagged) when removing old switch to terminal screw marked "BK".
- First Traveler wall box wire (note color as above) to terminal screw marked "RD". This traveler from the remote must go to the terminal screw on the dimmer marked "RD" or the Red dimmer lead.
- Second Traveler wall box wire (note color as above) to terminal screw marked "YL/RD". This traveler from the remote must go to the terminal screw on the dimmer marked "YL/RD" or the Yellow/Red dimmer lead.
- Remote terminal screw marked "WH" should have White insulation label affixed.
NOTE: If insulating label is not affixed to terminal screw marked "WH", use electrical tape to cover.
- Proceed to Step 6.

Step 5c 4-Way Wiring with Matching Remote (w/LEDs) for Controls with Neutral Connection Application:

NOTE: Electronic Low Voltage, Mark 10™, Quiet Fan Speed and Electronic Switch installations only.
NOTE: Dimmer is depicted.

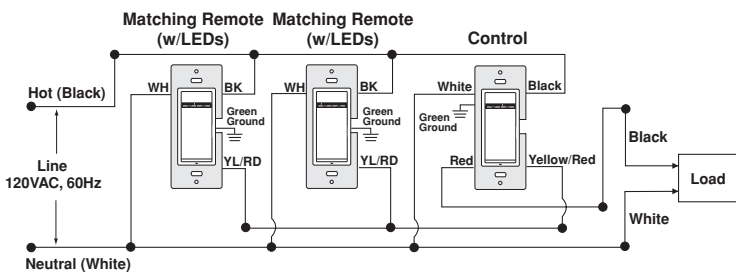
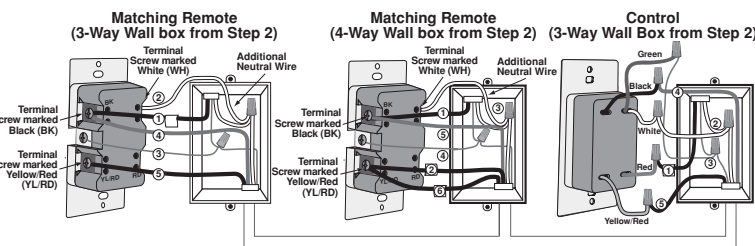

NOTE: The control must be installed in a wall box that has a Load connection. The matching remote must be installed in a wall box with a Line Hot connection and a Neutral connection. A Neutral wire to the matching remote needs to be added as shown. If you are unsure about any part of these instructions, consult a qualified electrician.

NOTE: Maximum wire length from control to all installed remotes cannot exceed 300 ft (90 m).

WIRING MATCHING REMOTE (4-Way wall box with Line Hot connection):
Connect wires per WIRING DIAGRAM as follows:

- Green or bare copper wire in wall box to Green terminal screw.
- First Traveler and Third Traveler wall box wire to remote terminal screw marked "BK" in 4-way box, and to terminal screw marked "BK" of the remaining remote in 3-way box.
- Second Traveler (tagged) and Fourth Traveler (tagged) wall box wire from control in 3-way box to remote terminal screw marked "YL/RD" in 4-way box and to terminal screw marked "YL/RD" of the remaining remote in 3-way box (note wire colors). This traveler from the remotes must go to the terminal screw marked "YL/RD" or Yellow/Red control lead.
- Line Neutral wall box wire to remote terminal screw marked "WH".

WIRING MATCHING REMOTE (3-Way wall box with Line Hot connection):
Connect wires per WIRING DIAGRAM as follows:

- Green or bare copper wire in wall box to Green terminal screw.
- Line Hot (common) wall box wire identified (tagged) when removing old switch and First Traveler wall box wire to control terminal screw marked "BK" or Black dimmer lead.
- Second Traveler wall box wire from control to remote terminal screw marked "YL/RD" (note wire color as above). This traveler from the remote must go to the terminal screw marked "YL/RD" or Yellow/Red dimmer lead.
- Line Neutral wall box wire to remote terminal screw marked "WH".

WIRING CONTROL (3-Way wall box with Load connection):
Connect wires per WIRING DIAGRAM as follows:

- Green or bare copper wire in wall box to Green terminal screw or Green dimmer lead.
- Load wall box wire identified (tagged) when removing old switch to terminal screw marked "RD" or Red control lead.
- First Traveler Line Hot to terminal screw marked "BK" or Black control lead.
- Remove Red insulating label from terminal screw marked "YL/RD" or Yellow/Red control lead.
- Second Traveler wall box wire (note color as above) to terminal screw marked "YL/RD" or Yellow/Red control lead. This traveler from the control must go to the terminal screw on the remote marked "YL/RD".
- Line Neutral wall box wire to terminal screw marked "WH" or White control lead.
- Proceed to Step 6.

Step 5d 4-Way Wiring with Coordinating Remote (no LEDs) for Controls with Neutral Connection Application:

NOTE: Electronic Low Voltage, Mark 10™, Quiet Fan Speed and Electronic Switch installations only. **NOTE:** Dimmer is depicted.

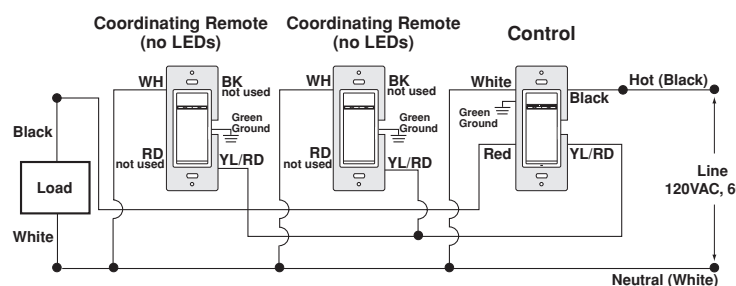
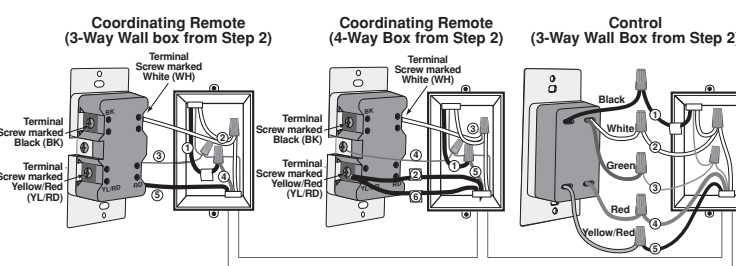

Step 5d cont'd

WIRING COORDINATING REMOTE (4-Way box):
Connect wires per WIRING DIAGRAM as follows:

NOTE: "BK" and "RD" terminals on coordinating remote are unused. Tighten both screws.

NOTE: Maximum wire length from dimmer to last remote is 300 ft (90 m).

- Green or bare copper wire in wall box to Green terminal screw.
- Connect First Traveler wall box wire to Third Traveler wall box wire (note wire colors) to terminal screw marked "RD" of remote in 4-way box, and to terminal screw marked "RD" of the remaining remote in 3-way box.
- Connect Second Traveler and Fourth Traveler wall box wire (note wire colors) to terminal screw marked "YL/RD" of remote in 4-way box, and to terminal screw marked "YL/RD" of the remaining remote in 3-way box. This traveler from the remotes must go to the terminal screw marked "YL/RD" or Yellow/Red control lead.
- Remove White insulating label from terminal screw marked "WH".
- Line Neutral wall box wire to terminal screw marked "WH".

WIRING CONTROL (3-Way box):
Connect wires per WIRING DIAGRAM as follows:

NOTE: The control must be installed in a wall box that has a Line Hot connection.

NOTE: Maximum wire length from control to all installed remotes cannot exceed 300 ft (90 m).

- Green or bare copper wire in wall box to Green terminal screw or Green control lead.
- Line Hot (common) wall box wire identified (tagged) when removing old switch to terminal screw marked "BK" or Black control lead.
- First Traveler wall box wire to terminal screw marked "RD" or Red control lead (note wire color as above).
- Remove Red insulating label from terminal screw marked "YL/RD" or Yellow/Red control lead.
- Second Traveler wall box wire to terminal screw marked "YL/RD" or Yellow/Red control lead (note wire color as above). This traveler from the control must go to the terminal screw on the remote marked "YL/RD".
- Line Neutral wall box wire to terminal screw marked "WH" or White control lead.

WIRING COORDINATING REMOTE (3-Way box):
Connect wires per WIRING DIAGRAM as follows:

NOTE: "BK" and "RD" terminals on coordinating remote are unused. Tighten both screws.

NOTE: Maximum wire length from control to last remote is 300 ft (90 m).

- Green or bare copper wire in wall box to Green terminal screw.
- Load wall box wire identified (tagged) when removing old switch to First Traveler (note color as above).
- Second Traveler wall box wire (note color as above) to terminal screw marked "YL/RD". This traveler from the remote must go to the terminal screw marked "YL/RD" or Yellow/Red control lead.
- Remove White insulating label from terminal screw marked "WH".
- Line Neutral wall box wire to terminal screw marked "WH".
- Proceed to Step 6.

Step 6 Testing your Remote prior to completely mounting in wall box:

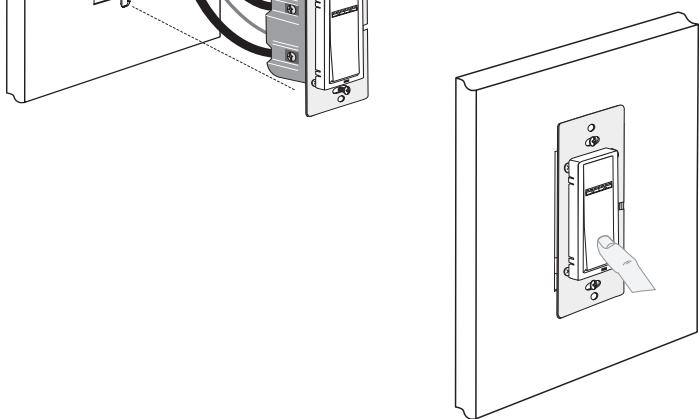
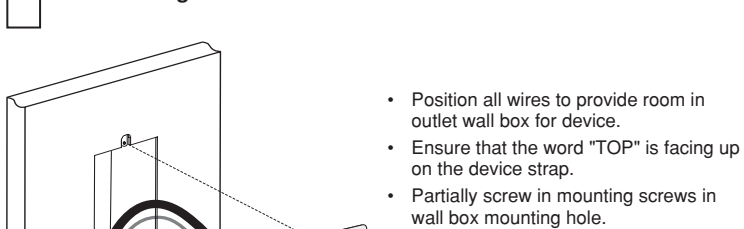

NOTE: Dress wires with a bend as shown in diagram in order to relieve stress when mounting device.

- Restore power at circuit breaker or fuse.
- See applicable operation section to ensure dimmer or switch is functioning properly.
- If lights do not turn ON, refer to the TROUBLESHOOTING section.

Step 7 Dimmer Remote Mounting:
TURN OFF POWER AT CIRCUIT BREAKER OR FUSE.



Step 8 Restore Power:
Restore power at circuit breaker or fuse. **Installation is complete.**

OPERATION

CLEANING: Clean with a damp cloth. **DO NOT** use chemical cleaners.

VP00R Dimmer Remote Operation (Device may be unlighted):

NOTE: The lights will turn ON at brightness set on dimmer's DIM/BRIGHT bar. The lighting can be switched from either the dimmer or the remote location.

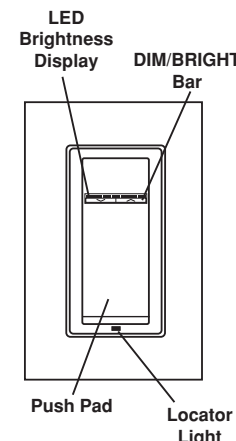

Push Pad (Default settings)

Turn ON from OFF position:
Tap – Lights turn ON to preset level.
Press and Hold – Lights turn ON to full bright.

Turn OFF from ON position:
Tap – Lights turn OFF.

DIM/BRIGHT Bar

BRIGHTEN:
Press right half of DIM/BRIGHT Bar – Lights brighten to desired level.

DIM:
Press left half of DIM/BRIGHT Bar – Lights dim to desired level.

If you continue to hold, the lights will DIM to minimum level and then turn OFF.
In the event of power outage or interruption the lights will reset to the last level when power is restored.

VP0SR Switch Remote Operation (Device may be unlighted):
The lighting can be switched from either the dimmer or the remote location.

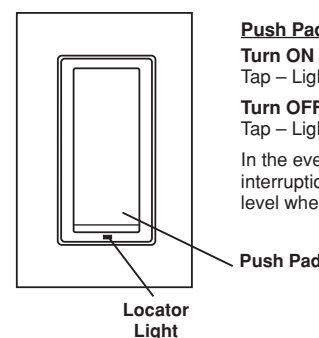

Push Pad (Default settings)

Turn ON from OFF position:
Tap – Lights turn ON to preset level.

Turn OFF from ON position:
Tap – Lights turn OFF.

In the event of power outage or interruption the lights will reset to the last level when power is restored.

VP00R-1L ADVANCED PROGRAMMING FEATURES FOR USE WITH VIZIA RF +™ ONLY

Definition of A Modes

A) LED Options: Sets single LED (default) or LED Bar to display the load status.

Program Mode A

To enter Program Mode A:

Press and hold the Push Pad and then the *right* half of the DIM/BRIGHT Bar (↗) for 5 seconds until all LEDs blink.

Upon releasing the Push Pad Locator LED will blink once per second to indicate Program Mode A, **LED Options**. To change the **LED Options** settings, release the Push Pad. This setting will automatically be saved and the device will exit Programming Mode.

LED Options	LED Brightness/Fan Speed Display
Default	Single LED
First toggle	LED Bar

TROUBLESHOOTING

- Lights Flickering**
 - Lamp has a bad connection.
 - Wires not secured firmly under terminal screws of dimmer and/or remote.
- Light does not turn ON and Locator LED does not turn ON**
 - Circuit breaker or fuse has tripped.
 - Lamp is burned out.
 - Lamp Neutral connection is not wired.
- Intermittent dimmer operation**
 - Minimum load is under 40W.
- Remote does not operate lights**
 - Ensure that total wire length does not exceed 300 ft (90 m).
 - Ensure that only Coordinating Remotes are used with Vizia rf +™ devices

For additional information, contact Leviton's Techline at 1-800-824-3005 or visit Leviton's website at www.leviton.com

Covered by one or more US & Foreign Patents and patents pending
Copyright © 2007 Leviton Manufacturing Co., Inc.
All Rights Including Trade Dress Rights Reserved

Eco-10™ (Eco Series) is a trademark and Hi-Lume® is a registered trademark of Lutron Electronics Inc.

FCC COMPLIANCE STATEMENT

This equipment has been tested and found to comply with the limits for a Class B Digital Device, pursuant to Part 15 of the FCC Rules. These limits are designed to provide reasonable protection against harmful interference in a residential installation. This equipment generates, uses, and can radiate radio frequency energy and, if not installed and used in accordance with the instructions, may cause harmful interference to radio communications. However, there is no guarantee that interference will not occur in a particular installation. If this equipment does cause harmful interference to radio or television reception, which can be determined by turning the equipment OFF and ON, the user is encouraged to try to correct the interference by one or more of the following measures:

- Reorient or relocate the receiving Antenna.
- Increase the separation between the equipment and the receiver.
- Connect the equipment into an outlet on a circuit different from that to which the receiver is connected.
- Consult the dealer or an experienced radio/tv technician for help.

LIMITED 5 YEAR WARRANTY AND EXCLUSIONS

Leviton warrants to the original consumer purchaser and not for the benefit of anyone else that this product at the time of its sale by Leviton is free of defects in materials and workmanship under normal and proper use for five years from the purchase date. Leviton's only obligation is to correct such defects by repair or replacement, at its option, if within such five year period the product is returned prepaid, with proof of purchase date, and a description of the problem to Leviton Manufacturing Co., Inc., Attn: Quality Assurance Department, 59-25 Little Neck Parkway, Little Neck, New York 11362-2591. This warranty excludes and there is disclaimed liability for labor for removal of this product or reinstallation. This warranty is void if this product is installed improperly or in an improper environment, overloaded, misused, opened, abused, or altered in any manner, or is not used under normal operating conditions or not in accordance with any labels or instructions. There are no other or implied warranties of any kind, including merchantability and fitness for a particular purpose, but if any implied warranty is required by the applicable jurisdiction, the duration of any such implied warranty, including merchantability and fitness for a particular purpose, is limited to five years. Leviton is not liable for incidental, indirect, special, or consequential damages, including without limitation, damage to, or loss of use of, any equipment, lost sales or profits or delay or failure to perform this warranty obligation. The remedies provided herein are the exclusive remedies under this warranty, whether based on contract, tort or otherwise.